2014 RAM 1500



RAM



CANADA'S LONGEST-LASTING^[1]



MOST FUEL-EFFICIENT PICKUP^[2]

THE 2014 *MOTOR TREND* TRUCK OF THE YEAR™

» **CANADA'S ONLY LIGHT-DUTY DIESEL PICKUP**

RAM EXCLUSIVE 14 » **THE ONLY LIGHT-DUTY PICKUP** to offer:

- » 8-speed Automatic Transmission.^[3]
- » Five-Link Coil Spring Rear Suspension.^[3]
- » Active-Level™ Four-Corner Air Suspension System.^[3]
- » RamBox® Cargo Management System.^[3]

From the moment you drive one, you know the 2014 Ram 1500 is the perfect truck. Look at the big picture, and Ram 1500 advantages are almost overwhelming.

Ram 1500 has pioneered some of the most impressive technologies and Class-Exclusive innovations in the market. Segment-Exclusive^[3] features such as the new high-torque and fuel-efficient 3.0-litre EcoDiesel V6, the proven TorqueFlite® 8 eight-speed automatic transmission, the versatile RamBox® Cargo Management System and the ultra-capable Active-Level™ Four-Corner Air Suspension System all give the Ram 1500 a capability that stands apart from the competition.

Percentage, by brand, of total pickups sold in the past 25 years, that are still on the road today^[1]

RAM	79%
CHEVY	72%
GMC	72%
FORD	66%

**RAM
1500**



FIRST EVER BACK-TO-BACK WINNER.

FUEL EFFICIENCY. IT'S NOT ONE THING. IT'S EVERYTHING.

Every curve was analyzed, every design element was examined. The final design gives you multiple aerodynamic and engineering efficiencies — like aero-shaped mirrors, an extended flexible air dam, carefully sculpted fog lamps

and a parabolic-shaped front end. Available wheel-to-wheel side steps, innovative Stop/Start Technology, the Segment-Exclusive Active Grille Shutters — all resulting in Best-in-Class Aerodynamics.^[3]



3.0L ECODIESEL V6.

THE ONLY LIGHT-DUTY DIESEL PICKUP IN CANADA. The all-new turbocharged 3.0L EcoDiesel V6 helps vault the 2014 Ram 1500 into powertrain leadership.

This silent and clean-burning engine is a turbocharged 60-degree, dual overhead cam (DOHC) 24-valve V6 that is so powerful, it actually rivals V8 power and capability.

Working with the class-exclusive 8-speed TorqueFlite[®] 8 automatic transmission,^[3] the 3.0L EcoDiesel V6 delivers exceptional low-end torque of 420 lb-ft at only 2,000 rpm. The outcome is outstanding performance, including towing capability up to 4,173 kg (9,200 lb), when properly equipped.

Refinements include a 29,000-psi Common Rail Fuel-Injection System enhanced with Multi-Jet II Shaping Technology enabling up to 8 fuel injections per combustion event. The EcoDiesel is also capable of running on environmentally friendly and renewable Biodiesel fuels up to a B-20 blend.

Long proven and built by world-class manufacturer VM Motori, the EcoDiesel is now in its sixth generation of production — and one you can count on for decades of hard labour.



240 HORSEPOWER 420 LB-FT OF TORQUE

» **LASTING DURABILITY.** *The engine is built with a cylinder block and bedplate constructed of high-strength Compact Graphite Iron, a forged steel crankshaft and connecting rods, durable aluminum alloy pistons, heat-treated aluminum cylinder heads and oil squirters for each piston.*

» **TURBO POWER.** *An electronically controlled and watercooled Variable Geometry Turbocharger enhances durability and capability. The system provides critical turbine power at low engine speeds helping to ensure optimal power and performance at all times.*

» **STATE-OF-THE-ART SELECTIVE CATALYTIC REDUCTION.** *This system reduces emissions and incorporates a unique Diesel Exhaust Fluid (DEF) system that alerts the driver to low DEF levels while also allowing the engine to maintain full power.*

» **COOL OIL. LONG LIFE. REDUCED COSTS.** *A standard engine oil cooler keeps the oil at peak operating temperatures, contributing to oil change intervals of up to 16,000 km!^[15]*

» **DUAL FUEL FILTRATION.** *This system enables exceptional separation of water from fuel for enhanced protection.*

RAM 1500 WITH THE ECODIESEL V6



RAM 1500 CLAIMS TOP HONOURS IN ALL CATEGORIES. An expert panel of judges tested 13 of the most popular half-ton pickups in Canada against each other in a rigorous multi-day challenge of intensive, real-world truck evaluations with a focus on capability, fuel consumption and features.

» **OVERALL WINNER OF THE CHALLENGE:**
Ram 1500 with the all-new 3.0L EcoDiesel V6

» **WINNER IN THE "UNDER \$45,000 CATEGORY":**
Ram 1500 Outdoorsman with the 3.6L Pentastar™ VVT V6

» **WINNER IN THE "OVER \$45,000 CATEGORY":**
Ram 1500 with the 3.0L EcoDiesel V6 and 5.7L HEMI® V8 claimed 1-2 finish

RAM: THIS IS HOW WE PUT POWER TO WORK.

THE 3.6L PENTASTAR™ VARIABLE VALVE TIMING (VVT) V6 FLEX FUEL ENGINE delivers a remarkable combination of power, long-term durability and extraordinarily low fuel consumption. Key features include cast aluminum cylinder heads, a high-pressure die-cast aluminum block, and dual independent camshaft phasing. A thermal management system with a pulse-width modulated fuel pump delivers fuel only when needed to further enhance efficiency.

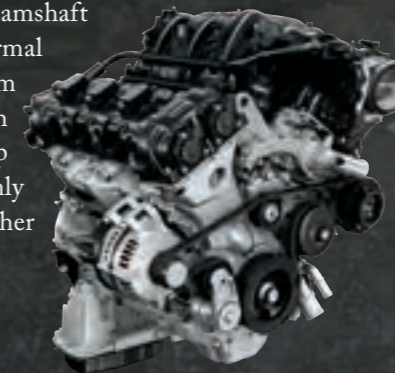

» **CLASS-LEADING GASOLINE ENGINE FUEL ECONOMY.^[4]** *Mated to the 8-speed automatic transmission, the Pentastar VVT V6 delivers up to 7.8 L/100 km (36 mpg) on the highway.**

» **VARIABLE VALVE TIMING (VVT).** *VVT controls the valves in the most efficient manner, allowing optimal engine breathing throughout the entire rpm range to deliver increased torque, fuel economy and emissions.*

305 HORSEPOWER 269 LB-FT OF TORQUE

THE LEGENDARY HEMI® VVT. It boasts one of the most impressive résumés in engineering history — and it's still one of the most powerful V8 engines in the large pickup segment. The 5.7-litre HEMI VVT V8 with FuelSaver MDS Technology is lauded for ultra-durable strength balanced by impressive efficiency. This V8 delivers exceptional towing and hauling, with excellent fuel efficiency — enhanced even further when paired with the Class-Exclusive TorqueFlite™ 8.^[3]



» **FUELSAVER MDS.** *The Multi-Displacement System seamlessly deactivates half of the cylinders, transforming the mighty V8 into a fuel-sipping four-cylinder.*

» **VARIABLE VALVE TIMING** *opens and closes valves to varying degrees depending on rpm, ensuring peak overall performance and increased torque, fuel economy and emissions.*

» **TWO SPARK PLUGS PER CYLINDER** *to burn fuel with the greatest efficiency, ensuring consistent, clean and complete combustion.*



395 HORSEPOWER 407 LB-FT OF TORQUE

THE FIRST 8-SPEED AUTOMATIC^[3] IN A PICKUP. The TorqueFlite[®] 8 encapsulates our commitment to innovation, comfort and capability. Principal features include:

• **A WIDE GEAR-RATIO SPREAD WITH CLOSE STEPS** that help deliver excellent shift quality and allow the engine to spend more time at lower rpm — helping enhance fuel economy.

• **ELECTRONIC SHIFT MAPPING** that includes 40 shift maps, each tuned for optimal shifting in varying road and driving conditions.

• **A THERMAL MANAGEMENT SYSTEM THAT** quickly warms the transmission fluid, improving overall performance and daily fuel efficiency.

• **THE SEGMENT-EXCLUSIVE^[3] ELECTRONIC ROTARY DIAL SHIFTER** is intuitive, and frees up space for additional storage.

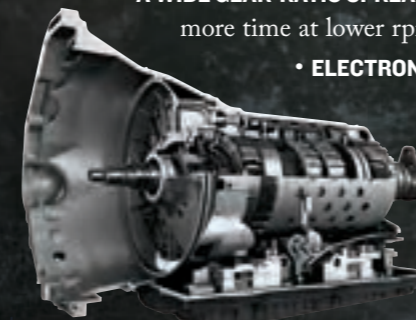

*See fuel economy chart on page 22 for full details.

OTHERS SIMPLY PALE IN COMPARISON.

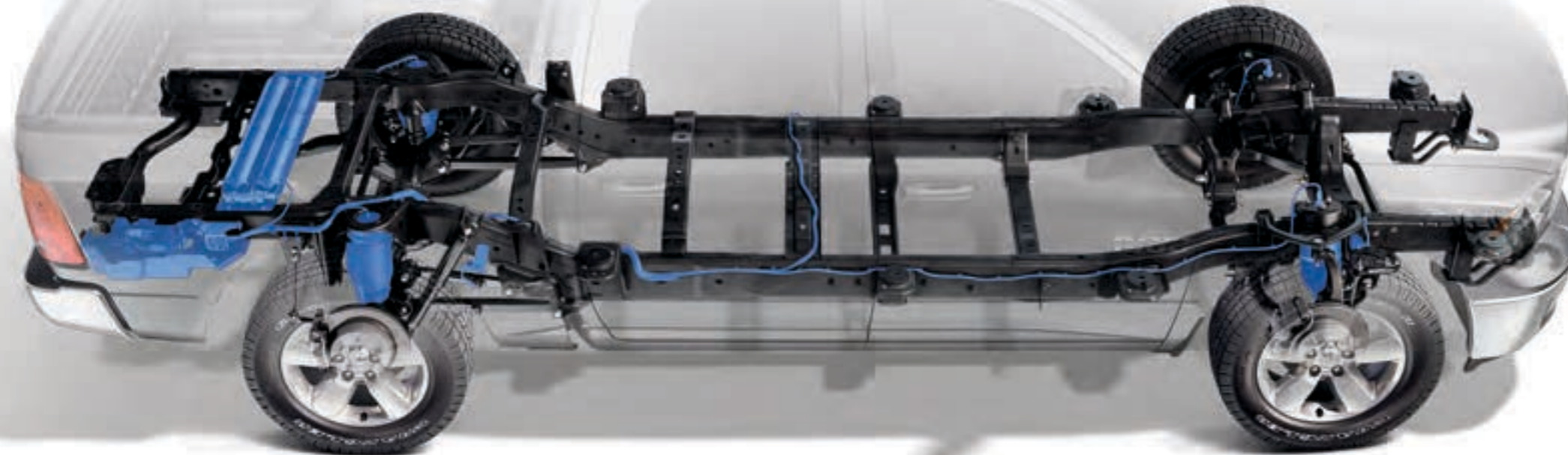

The structural rear bumper is rated for Class III assignments and easily handles trailers up to 2,268 kg (5,000 lb).

The available Class IV hitch receiver bolts directly to the frame of your Ram 1500. All models feature the 4- and 7-pin trailer tow connectors as standard equipment.

The 2014 Ram 1500 employs lightweight high-strength steel. The results give you a tough full-size pickup with exceptional capability and Best-in-Class fuel economy.^[2]

Ram 1500 rides on a partially hydroformed and low-torsion ladder frame with fully boxed side rails; ride quality, road manners, hauling and interior comfort are superb.

Hydroformed engine compartment inner structure enables the fenders to become simple bolt-on panels that are easier and less costly to replace.

Galvanized body panels offer superb corrosion protection and bake-hardened steel for outer door panels offer enhanced resistance against dents.

ULTRA-CAPABLE 4x4 AUTHORITY.

THE PART-TIME TRANSFER CASE. The Borg-Warner® transfer case available on the 2014 Ram 1500 is ideal for off-road, farm, industrial and leisure activities. It features two speeds with three operating ranges, plus neutral. It is electronically operated with instrument panel-mounted activation. Standard on Ram ST, SLT and Outdoorsman 4x4 models.

THE ON-DEMAND TRANSFER CASE. Long proven on Ram 1500 models, this two-speed transfer case offers four operating modes, plus the neutral position. It is electronically operated with instrument panel-mounted activation. The 4WD Auto Mode allows for all-weather operation — with no driver input required. Standard on Ram Big Horn, Sport, Laramie, Laramie Longhorn and Laramie Limited 4x4 models.

TWO CLASS-EXCLUSIVE^[3] SUSPENSIONS: GREAT HAULING, EXCEPTIONAL COMFORT.

THE AVAILABLE ACTIVE-LEVEL™ FOUR-CORNER AIR SUSPENSION SYSTEM.

This is a level of ride quality and convenience that separates Ram from the rest. The remarkable Active-Level Four-Corner Air Suspension System features automatic levelling while under heavy payload, with five distinct ride levels (modes), all controlled with fingertip ease on the integrated switch bank or the key fob.

+ OFF-ROAD 2 MODE Provides excellent ground clearance for the path and trail, with the greatest angles for approach, departure and breakover. Difference from Normal ride height: **+51mm (+2.0 in).**

+ OFF-ROAD 1 MODE Outstanding ride balance, with an extra degree of clearance when you need it. Difference from Normal: **+30mm (+1.2 in)** front; **+22mm (+0.9 in)** rear.

+ NORMAL RIDE HEIGHT The most comfortable balance of ride and handling for everyday driving.

+ AERO MODE Aero automatically lowers the vehicle at highway speeds, reducing aerodynamic drag and "body roll"; the improvements to fuel efficiency are measurable. Difference from Normal: **-27mm (-1.1 in).**

+ ENTRY/EXIT MODE Automatically lowers the entire vehicle for easier ingress/egress, loading/unloading, trailer hooking/unhooking. Difference from Normal: **-53mm (-2.1 in)** front; **43mm (-1.7 in)** rear.

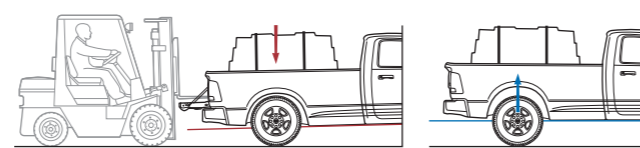

RAM EXCLUSIVE 14 ACTIVE-LEVEL TECHNOLOGY. For typical pickups, a heavily loaded cargo bed produces obvious sag and points headlights up instead of forward. The available Ram Active-Level Four-Corner Air Suspension System makes all of that history, by counteracting the weight, levelling out the chassis for an even ride and giving you a comfortable horizontal plane with properly directed headlamps.



OPERATION IS THE DRIVER'S CHOICE. The available Active-Level Four-Corner Air Suspension System is fully automatic or controllable with fingertip ease through a button on the dashboard-mounted switch bank or the key fob.

THE MULTILINK COIL SPRING REAR SUSPENSION.

RAM EXCLUSIVE 14 IN A CLASS OF ITS OWN: CAPABILITY MEETS COMFORT. The standard rear suspension on the 2014 Ram 1500 model is unmatched in the industry — unless you're including freight trains in your analysis. The Class-Exclusive^[3] multilink coil spring rear suspension technology is the preferred suspension system for rail cars. Fact: this suspension design offers strength, durability and exceptional ride comfort without sacrificing capability.

Two heavy-duty steel longitudinal links on each side are mounted to the frame and are tuned to offer outstanding performance during hauling and cruising.

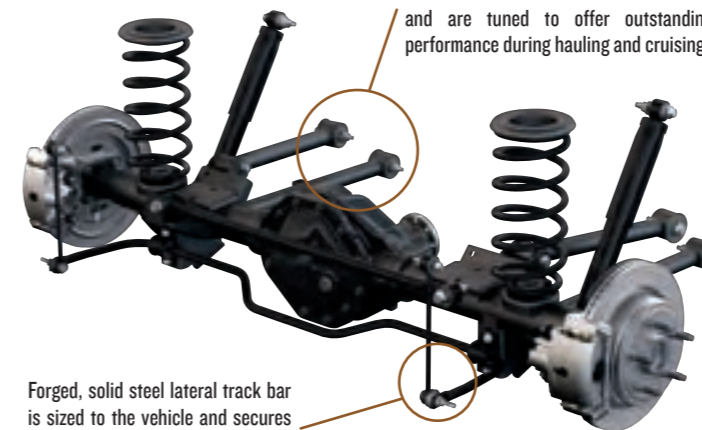

Forged, solid steel lateral track bar is sized to the vehicle and secures to the frame (and then to the axle) to control body roll during cornering.

ACHIEVING THE STATUS OF CANADA'S LONGEST-LASTING PICKUP^[1] — THE HARD WAY.

This is what it takes: begin as a concept, undergo rigorous computer-aided engineering processes, become a prototype — and then subject the vehicle to treatments far worse than you will ever attempt. From testing chamber to gruelling on-road trials in conditions that range from 49°C (120°F) deserts to -29°C (-20°F) arctic climates, it's nothing but brutal. The results are incomparable — and they are measured in quality.

Information Provided by:





BRING IT ALL HOME.

The 2014 Ram 1500 is ready for the toughest towing assignments, pairing uncompromising torque and frame strength with capability critical to the task at hand: count on precise handling, performance, confident take-off from full stops, and effortless acceleration and merging followed by comfortable highway cruising.

The upshot: no-nonsense and no-worry towing and hauling capability that offers control of the trailer and command of the terrain. This is Ram trucks at their best.

PUT ALL YOUR BEST BEHIND YOU: your horse trailer, your vintage car, your trusted camper. Comprehensive capability includes the available ParkView® Rear Back-up Camera^[5] with dynamic grid lines for perfect hitch alignment. Available integrated Class IV hitch receiver. Standard 4- and 7-pin wiring harness. Standard Electronic Stability Control^[6] system with Trailer Sway Control. Top it off with the available integrated Trailer Brake Controller that lets you custom-tune your Ram for complex trailers — even those with multiple axles — and you can easily go with the tow.



BRIGHT LIGHTS. BIG TOWING. Ideally positioned in the rear bumper well, the standard 4- and 7-pin trailer tow harness connector keeps the connections far from dirt and debris; adjacent illumination makes it a breeze to hitch or unhitch a trailer at night.



MANAGE YOUR TOWING WITH FINGERTIP CONTROL. The integrated switch bank is intuitively located on the front center stack and manages a host of towing and interior features, including Trailer Brake Control, the Stop/Start system, the Electronic Stability Control^[6] system, Tow/Haul mode, heat and ventilation for seats, the multiple modes of the available Active-Level™ Four-Corner Air Suspension System and the heated steering wheel (if equipped).

SURROUNDED BY SAFETY.

New technology for Ram 1500 gives this pickup a major upgrade in terms of convenience and security. The available new Park-Sense® Front and Rear Park Assist System^[5] is all-new technology that simplifies parking and manoeuvring.

Six Park-Sense sensors located in the front bumper and four located in the rear bumper, monitor the areas within the sensors' field of view. The front sensors can detect obstacles from a distance up to 1193 mm (47 in) and the rear sensors from a distance up to 2006 mm (79 in). Readouts located in the cluster display team up with audible chimes to notify the driver of any proximity to the front and/or rear objects. For more, visit ramtruck.ca



REMOTE KEYLESS ENTER 'N GO™ This available feature utilizes a custom radio frequency that lets the door locks and your personalized keyless fob communicate with each other. No need for keys in hand: with the fob in a pocket or bag, the driver can approach the locked vehicle, pull the door handle, enter — and go. With the remote keyless locking system, the same telematics apply to locking and unlocking the tailgate, doors and available RamBox.® A keyless push-button Stop/Start ignition completes the system.

AUTO HIGH-BEAM HEADLAMP CONTROL. This available system automatically toggles between low and high beam to maximize nighttime vision — and gives oncoming drivers welcome relief from potential high-beam intensity. Intuitive and intelligent, the system effectively ignores ambient lighting (street lights, sign reflections, buildings, etc.); when cresting a hill, it instantly switches to low-beam light output.

HIGH-PERFORMANCE LIGHTING. These available 70-millimetre projector beam headlamps ensure superb forward- and spread-light performance, using bi-functional technology (high and low beams in a single headlamp) to increase the peripheral spread light.

REMOTE START. This available system lets you start the vehicle from more than 91 metres away.

PARKVIEW® REAR BACK-UP CAMERA.^[5] Features active grid lines that adjust the guide paths as the steering wheel is turned to aid in aligning trailers and hitches. The available system uses a tailgate-mounted hidden camera and conveniently displays the image on the radio screen or rearview mirror (depending on radio system).

ELECTRONIC STABILITY CONTROL (ESC)^[6] So important to towing control and daily safety and security, it's standard on every Ram 1500. ESC is so refined that it can anticipate the intended path of the vehicle to optimize vehicle dynamics. ESC features multiple technologies:

- **ANTILOCK BRAKE SYSTEM (ABS).** This four-channel system monitors each wheel's speed and allows back-up braking should one of the two braking circuits be compromised. The **ELECTRONIC BRAKE-FORCE DISTRIBUTION** regulates braking pressure from front to rear to minimize stopping distances for ideal control.
- **TRACTION CONTROL.** Integrated with the ABS, it regulates wheel spin at all speeds. Impending wheel slip during acceleration results in throttle control to reduce torque; in extreme situations — accelerating from pavement to ice — it will selectively apply brakes to maintain control. It can be turned off with a console-mounted button.
- **READY ALERT BRAKING.** The system senses when the driver lifts his foot from the accelerator, and then instantly applies a slight (and imperceptible) brake force to ensure that brake pads and discs are correctly lined up should a sudden or emergency stop be necessary.
- **RAIN BRAKE SUPPORT.** Activated by the windshield wipers, the brake calipers pulse against the rotor, removing water from the pads.
- **HYDRAULIC BOOST COMPENSATION.** Should a failure occur in the vacuum brake booster or any related line (e.g., a rupture from tough off-roading), the brake controller will run the ABS pump and the brakes will perform as normal until the failure is serviced.
- **TRAILER SWAY CONTROL.** This system detects trailer yaw and automatically compensates by applying selective brake pressure on the tow vehicle's opposite side to counteract and reduce the sway.
- **HILL START ASSIST.** While on hills or inclines, the system holds the vehicle stationary for two seconds after the brakes have been released.



LUXURY. IT'S ABOUT YOU.



THE NEWEST ADDITION TO LUXURY: THE 2014 RAM 1500 LARAMIE LIMITED MODEL. The new Laramie Limited features Black heated and ventilated premium leather seats, luxury door trim panels, leather-wrapped grab handles, luxury front and rear floor mats, a premium instrument cluster and a leather steering wheel with real wood.

Outside, its sleek monotone paint finish is accented by wheel-to-wheel side steps, and authoritative 20-inch aluminum wheels with chrome pockets.

Technology is comprehensive and impressive, with Remote Keyless Enter 'n Go™, Auto High-Beam Headlamp Control, rain-sensitive windshield wipers, the class-exclusive Active-Level™ Four-Corner Air Suspension System and more.

Reaching for luxury puts the benchmark at your service: the Ram 1500 Laramie, Laramie Longhorn and new Ram Limited models.

These workhorses serve up a degree of sophistication and design that put these Ram owners in an enviable league of their own. Both the interior and exterior offer distinctive touches. Instant eye and street appeal start with opulent two-tone or monotone finishes (depending on model), chrome accents and authoritative 20-inch wheels.

Inside, Ram 1500 Laramie models distinguish themselves with specialized finishes and treatments with designer-level accessories. The leather-trimmed interior of the Ram Laramie, the heated and ventilated front bucket seats, and the heated, leather-wrapped steering wheel with audio controls offer a big payoff in comfort. Now add a 7-inch, full-colour customizable in-cluster display centre and dozens more amenities. The Ram Laramie Longhorn, shown above, has unique burled walnut accents throughout the cabin.

Information Provided by:



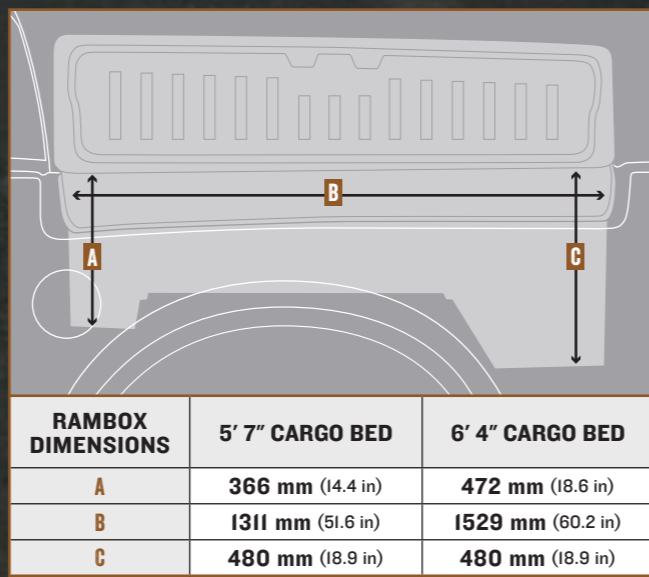

RAM EXCLUSIVE 14 THE RAMBOX® CARGO MANAGEMENT SYSTEM.

Ram 1500 offers a number of cab and cargo bed configurations to meet your needs. Storage is extensive both inside and out, including three cab sizes (Regular Cab, Quad Cab® and Crew Cab) and three cargo bed lengths (5-foot 7-inch, 6-foot 4-inch and 8-foot) depending on the model. And when it comes to storage versatility, no other truck manufacturer can match the Ram 1500 lineup.

Standing alone in its class, the innovative RamBox Cargo Management System is available for all trim levels with 5-foot 7-inch and 6-foot 4-inch beds.

This multifaceted storage system includes two large, drainable, illuminated and lockable storage compartments, one on each

side of the cargo bed, and each spacious enough to hold various size sports equipment or power tools.

The system also includes a cargo bed extender/divider (smartly stored at the front of the bed when not needed), which lets you customize the cargo bed area and extend usable bed length (reverse it to divide the bed for specific cargo-carrying needs). A built-in cargo bed rail system with four adjustable cleats offers secure tie-down points for cargo.

REMOTE KEYLESS LOCKING FOR DOORS, TAILGATE AND RAMBOX. This available feature lets you lock or unlock all Ram 1500 doors, rear liftgate and RamBox compartments (if equipped) with a simple click on the fob.

MOVE WITH AUTHORITY.

OUTSTANDING STORAGE VERSATILITY.

Fold up the seat in the Ram 1500 Crew Cab and Quad Cab® models, and you're looking at the convenience of an available fold-flat load floor. The space behind the front seat of Ram 1500 Regular Cab is so large, you can stash three industrial-sized 18.9-litre containers back there. The fact is, the interior conveniences afforded by intelligent storage in the new 2014 Ram 1500 make short trips or long journeys a breeze. Cargo storage conveniences include:

DUAL GLOVE BOX AND CONSOLE TREATMENTS. Designers took steps to offer maximum storage capability at every opportunity. Dual glove boxes feature large upper and lower storage areas for enhanced interior storage and convenience. The centre console armrest bins have three available integrated cup holders and provide access to the available media port for connectivity.

VERSATILITY DESIGNED TO FLOOR YOU. Ram Crew Cab models have long distinguished themselves with interior roominess — but that's not their only distinction. The class-exclusive in-floor storage bins^[3] on these spacious pickups offer multi-capacity convenience: removable and insulated, they can hold ice to keep beverages and food cold. They're perfect to stash valuables and small tools.

UNDER THE REAR SEAT: IT'S OUT OF SIGHT. While the new 2014 Ram 1500 features the most interior, trim and material refinements in Ram 1500 history, one success story continues: the rear underseat storage in Ram 1500 Crew Cab and Quad Cab models. Lift the seat, store and close — whether it's the tools of the trade, sports equipment or things just better left out of sight, this is one ideal storage solution.

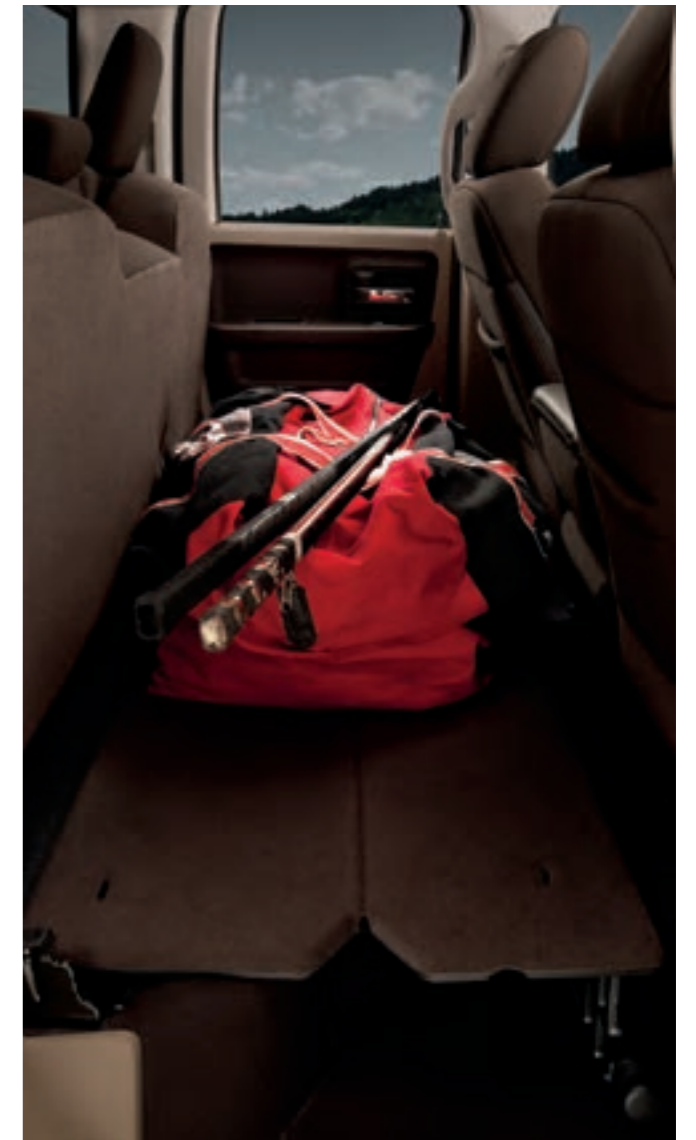

REAR UNDERSEAT STORAGE



IN-DOOR STORAGE



DUAL GLOVE BOXES

Provided by:
Properly secure all cargo.



BRILLIANT ELECTRONICS.

RAM: HELPING THE INFORMATION AGE GROW UP.

Here's a respectful nod to the past as we ride on the technology of the future. Each trim level of the 2014 Ram pickup comes to work with an individual and bold instrument panel cluster and Electronic Vehicle Information Centre. Select upscale models feature a six-ring instrumentation cluster that takes its design cues from antique watches and vintage jewelry.

Unlike anything in the segment, select Ram 1500 models feature driver-oriented technology that enhances convenience and responsible on-road action. Among them: a segment-exclusive,^[3] full-colour 7-inch customizable in-cluster display. The multiview display screen features personalized settings for audio, compass, temperature settings, fuel economy, trip info, cruise control, trailer braking, vehicle status and engine performance.

This technology focuses on keeping eyes on the road and hands on the wheel — which is why the dynamic information screens are accessed using an intuitive “roller-menu” controlled by a steering wheel-mounted toggle switch, and why the interface for navigation includes convenient voice commands.

The Ram Powernet electrical architecture employs high- and low-speed data networks to communicate with and connect between in-vehicle system modules. You'll find information about virtually every facet of vehicle operation through multiple “smart modules” that basically talk to each other.

What it all boils down to is knowledge: Ram trucks deliver a wealth of information with fingertip-operated ease. This is technology driving to be the best.



SHOWN ABOVE: SOME OF THE DOZENS OF DISPLAY SCREEN MENUS.



A FULL SPECTRUM OF COMMUNICATIONS TECHNOLOGY.

Our world is one of interconnected business and leisure communications that happen at the speed of life. The upgraded systems offered by the Uconnect™ multimedia centres provide innovative simplicity that puts you in control. Available features include:

ENTERTAINMENT. SiriusXM Satellite Radio^[7] with dozens of commercial-free channels. Enjoy premium sound from multi-speaker Alpine® audio systems, the CD/DVD player, USB connectivity and Bluetooth® streaming audio.

PHONE.^[8] It's all here: Bluetooth pairing of multiple phones, contact syncing, voice-activated hands-free calling and text messaging. The system can also automatically synchronize up to 1000 entries from your Bluetooth compatible phone's address book^[9]

NAVIGATION.^[10] Intuitive, user-friendly GPS systems with turn-by-turn directions and available 3-D displays make travel easy.

VOICE COMMAND.^[8] Allows you to use your voice to select radio stations as well as make/receive calls and select destination entries with the available navigation.

CONTROLS. Controlling functions while driving has never been easier — or more responsible. All your radio, touch-screen and steering wheel controls are designed to be easy to find and easy to use. Adjust your seat or cabin temperature, select a music station, or make a call without taking your eyes from the road.^[8]



Information Provided by:



ST REGULAR CAB / QUAD CAB® / CREW CAB



POWERTRAIN

- 5.7L HEMI® VVT V8 with FuelSaver/Multi-Displacement System (MDS) and 6-speed automatic (25A)
- 3.6L Pentastar™ Variable Valve Timing (VVT) V6 with 8-speed automatic (22A)
- 3.0L EcoDiesel V6 with 8-speed automatic (28B)

» STANDARD EQUIPMENT «

INTERIOR AMENITIES

- Air conditioning
- Heavy-duty vinyl 40/20/40 split bench seat
- Rear heavy-duty vinyl flip-up bench seat (Quad/Crew Cab)
- Front-seat centre armrest with three cup holders
- Cruise control and tilt steering column
- Uconnect™ 3.0 multimedia centre
- 1.5-amp USB port for personal devices
- 3.5-inch Electronic Vehicle Information Centre
- 12-volt auxiliary power outlets
- Power door locks and front windows with one-touch up/down (Quad/Crew Cab)
- Rear in-floor storage (Crew Cab)
- Rear underseat storage wells (Quad/Crew Cab)

EXTERIOR FEATURES

- 17-inch lightweight steel wheels
- P265/70R17 BSW All-Season Goodyear® tires
- Power, heated 6- x 9-inch black mirrors, manual-folding (Quad/Crew Cab)
- Quad lens halogen headlamps
- Black grille, door handles and front/rear bumpers
- Grey upper fascia

SAFETY & SECURITY

- Six air bags including driver and front-passenger, side-curtain and front seat side-mounted^[1]
- Four-wheel disc antilock brakes with Brake Assist
- Automatic headlamps
- Tire Pressure Monitoring System with display screen
- Driver and front-passenger knee bolsters
- Electronic Stability Control^[2] with Hill Start Assist, Trailer Sway Control, Electronic Roll Mitigation, Rain Brake Support, Ready Alert Braking and Traction Control

CAPABILITY & FUNCTIONALITY

- Front suspension with upper and lower control arms, coil springs and HD shock absorbers
- Rear suspension with multilink coil spring and heavy-duty shock absorbers
- 4- and 7-pin trailer wiring harness
- Electronic shift-on-the-fly part-time transfer case (4x4 only)
- Front stabilizer bar
- Rear stabilizer bar (Quad/Crew/4x4)

SXT REGULAR CAB / QUAD CAB / CREW CAB



POWERTRAIN

- 5.7L HEMI VVT V8 with MDS and 6-speed automatic (25A)
- 3.6L Pentastar VVT V6 with 8-speed automatic (22A)

» ENHANCEMENTS VS. ST «

INTERIOR AMENITIES

- Cloth 40/20/40 bench seat
- SiriusXM Satellite Radio including one-year subscription^[7]
- Carpet floor covering
- Floor mats

EXTERIOR FEATURES

- Chrome grille with black hex-link insert
- 17-inch aluminum wheels
- Chrome front and rear bumpers

SAFETY & SECURITY

- Remote keyless entry (Quad/Crew)

SLT REGULAR CAB / QUAD CAB / CREW CAB



POWERTRAIN

- 3.6L Pentastar VVT V6 with 8-speed automatic (22G)
- 5.7L HEMI VVT V8 with MDS and 8-speed automatic (26G)
- 3.0L EcoDiesel V6 with 8-speed automatic (28G)

» ENHANCEMENTS VS. SXT «

INTERIOR AMENITIES

- Overhead console
- Uconnect 5.0 multimedia centre
- Hands-free communication^[8] with Bluetooth® streaming audio
- Premium door trim with map pocket
- Rear power sliding window (Quad Cab/Crew Cab)
- Instrument panel colour-keyed accents
- Temperature and compass displays
- Power door locks and front windows with one-touch down (Regular Cab)
- Traveller and mini trip computer

EXTERIOR FEATURES

- Body-colour upper fascia
- Body-colour and chrome door handles

OUTDOORSMAN QUAD CAB / CREW CAB



POWERTRAIN

- 3.6L Pentastar™ VVT V6 with 8-speed automatic (22T)
- 5.7L HEMI® VVT V8 with MDS and 8-speed automatic (26T)
- 3.0L EcoDiesel V6 with 8-speed automatic (28T)

» ENHANCEMENTS VS. SLT «

INTERIOR AMENITIES

- Front and rear rubber floor mats

EXTERIOR FEATURES

- Body-colour grille
- Black lower two-tone paint
- Black painted front/rear bumper
- Black painted fender flares
- Fog lamps

CAPABILITY & FUNCTIONALITY

- Tow hooks
- Transfer case skid plate shield (4x4 models)
- Front suspension skid plate (4x4 models)
- LT265/70R17E OWL Goodyear® On-/Off-Road tires (N/A with Crew Cab 4x2 6'4" box)
- Class IV hitch receiver (4x4 models)
- Rear extra-heavy-duty shock absorbers (4x4 models)
- Antispin differential rear axle (4x4 models)
- 121-litre fuel tank

BIG HORN QUAD CAB / CREW CAB



POWERTRAIN

- 5.7L HEMI VVT V8 with MDS and 8-speed automatic (26X)
- 3.0L EcoDiesel V6 with 8-speed automatic (28X)

» ENHANCEMENTS VS. SLT «

INTERIOR AMENITIES

- Premium 7-inch customizable in-cluster display centre
- Overhead console with universal garage door opener^[2]
- Sun visors with illuminated vanity mirrors
- Auto-dimming rearview mirror
- Rear dome lamp with on/off switch
- Leather-wrapped steering wheel with audio controls
- Glove box and underhood lamps

EXTERIOR FEATURES

- 20-inch aluminum wheels
- Chrome power-folding, 6- x 9-inch heated mirrors with supplemental turn signals and courtesy lamps
- Chrome grille with chrome billets
- Chrome tubular side steps
- Fog lamps
- P275/60R20 BSW All-Season Goodyear tires

CAPABILITY & FUNCTIONALITY

- Electronic shift-on-demand transfer case (4x4 models)
- Dual rear exhaust with bright tips
- Tow hooks

SPORT QUAD CAB / CREW CAB



POWERTRAIN

- 5.7L HEMI VVT V8 with MDS and 8-speed automatic (26L)

» ENHANCEMENTS VS. BIG HORN «

INTERIOR AMENITIES

- Cloth high-back front bucket seats
- LED interior lighting
- Full-length floor console
- Rear 60/40 split-folding seat
- Power 10-way driver's seat, including 2-way lumbar adjust
- Fold-flat rear load floor storage
- Uconnect™ 8.4A multimedia centre, NAV Ready
- Premium door trim panel
- 115-volt auxiliary power outlet

EXTERIOR FEATURES

- 20-inch polished aluminum wheels with Silver painted pockets
- Body-colour grille with bright billets
- Body-colour front fascia and rear bumper
- Body-colour exterior mirrors and door handles
- Body-colour power-folding, 6- x 9-inch heated, auto-dimming mirrors, with supplemental turn signals and courtesy lamps
- Premium bi-function halogen projector headlamps with Black surround
- Premium LED taillamps (turn/stop/tail/running lights) with black surround
- Dual rear exhaust with bright tips
- P275/60R20 OWL All-Season Goodyear tires

R/T REGULAR CAB

» ENHANCEMENTS VS. SPORT «

- 7 Alpine® speakers with 8-channel amplifier
- 22-inch forged polished aluminum wheels
- Sport Performance Hood
- Body-colour grille with black mesh insert and R/T badge
- P285/45R22 BSW All-Season Goodyear tires

» MULTIMEDIA CENTRES «



UCONNECT 3.0

- AM/FM/MP3
- Media Hub including an auxiliary input jack and remote USB port
- iPod® mobile device integration
- SiriusXM Satellite Radio with one-year subscription^[7] (optional on ST models)
- Speed-adjusted volume



UCONNECT 5.0

- Uconnect 3.0 features plus:*
- 5-inch full-colour high-resolution touch-screen display
 - Bluetooth® connectivity for hands-free^[8] phone, streaming audio, voice command, preset text reply and incoming voice text message reader^[9]
 - Personalization of Electronic Vehicle Information Centre
 - Rearview camera^[9]-ready



UCONNECT 8.4A

- Uconnect 5.0 features plus:*
- 8.4-inch full-colour high-resolution touch-screen display
 - Navigation ready^[10]
 - Remote SD card slot
 - HVAC control integration
 - SMS response (dictation)



UCONNECT 8.4AN

- Uconnect 8.4A features plus:*
- 3D navigation^[10] with "one-shot" voice navigation^[8]



» PAINTS «



Black



Black Gold Pearl



True Blue Pearl



Maximum Steel Metallic



Blue Streak Pearl



Bright White



Bright Silver Metallic



Granite Crystal Metallic



Flame Red



Deep Cherry Red Crystal Pearl



Prairie Pearl



Western Brown Pearl

» WHEELS «



17-inch Lightweight Steel
Standard on ST and Tradesman



17-inch Tech Silver Aluminum
Standard on HFE, SXT, SLT and Outdoorsman



17-inch Chrome-Clad Aluminum
Available on Big Horn, SLT and Laramie



20-inch Aluminum
Standard on Express
Packaged with SLT Décor Group
Black painted version available on Outdoorsman



20-inch Aluminum
Available on Express



20-inch Chrome-Clad Aluminum
Standard on Big Horn



20-inch Polished Aluminum with Silver Painted Pockets
Standard on Sport
Available on SLT with SLT Décor Group



20-inch Chrome-Clad Aluminum
Standard on Laramie



20-inch Multi-Clad Polished Aluminum with Accent-Painted Gold Inserts
Standard on Laramie Longhorn with Two-Tone Exterior Paint



20-inch Polished Aluminum with Accent-Painted Silver Inserts
Standard on Laramie Longhorn with Monotone Exterior Paint



20-inch Aluminum with Accent-Painted Chrome Inserts
Standard on Laramie Limited



22-inch Forged Polished Aluminum
Standard on Sport R/T

» FABRICS «



Heavy-Duty Vinyl — Diesel Grey
Standard on ST, Tradesman and Express



Cloth — Diesel Grey
Standard on SXT, HFE, SLT, Outdoorsman and Big Horn. Available on ST, Tradesman and Express



Cloth — Canyon Brown
Standard on HFE, SLT, Outdoorsman and Big Horn



Cloth — Diesel Grey
Available on SLT, Outdoorsman and Big Horn



Cloth — Canyon Brown
Available on SLT, Outdoorsman and Big Horn



Sport Mesh Cloth with Vinyl — Black
Standard on Sport and R/T



Leather-Faced with Perforated Inserts — Black
Available on Sport



Leather-Faced with Perforated Inserts — Black
Standard on Laramie



Leather-Faced with Perforated Inserts — Light Frost Beige
Standard on Laramie



Premium Leather with Perforated Inserts — Cattle Tan
Available on Laramie Longhorn



Premium Leather with Perforated Inserts — Canyon Brown
Available on Laramie Longhorn



Premium Leather with Perforated Inserts — Black
Standard on Laramie Limited



Premium Leather with Perforated Inserts and Laser Etching — Canyon Brown
Standard on Laramie Longhorn

AUTHENTIC RAM ACCESSORIES.



Above: Ram 1500 Crew Cab ST in Bright Silver Metallic shown with Side Window Air Deflectors, Wheel Flares, Stainless Steel Wheel-to-Wheel Tubular Side Steps, RamBox® Cargo Management System, Sliding Toolbox and RamBox Toolbags. Properly secure all cargo.



ENGINEERED FOR MAXIMUM PERFORMANCE.

TAKE IT PERSONALLY. WE DO. You've made the move to your new 2014 Ram 1500. Now the fun starts.

Outfit your new Ram 1500 with Authentic Accessories from Mopar®, and you're making a personal statement that addresses comfort, convenience, style and capability. These innovative parts and accessories deliver the same demanding tolerances as your new Ram, because Mopar technicians and engineers work closely with Ram designers to give you OEM quality at every turn. Fit and finish are exacting and precise, created with diagnostic equipment that delivers proven quality. And the selection is so diverse, you can personalize your Ram like no other.

There are literally hundreds of Authentic Accessories from Mopar for your new Ram. Featured below are some of our most popular choices. You'll find much more when you visit mopar.ca



ROLL-UP TONNEAU COVER



ALUMINUM LADDER RACK



UNDER-THE-RAIL BEDLINER

RAM 1500 TOWING AND PAYLOAD HIGHLIGHTS.

GAS ENGINES													
TOWING (conventional ball & hitch)* kg (lb)				REGULAR CAB				QUAD CAB®		CREW CAB			
				1.9m (6'4") Box		2.4m (8') Box		1.9m (6'4") Box		1.7m (5'7") Box		1.9m (6'4") Box	
Engine	Auto Trans	Axle Ratio	GCWR	4x2	4x4	4x2	4x4	4x2	4x4	4x2	4x4	4x2	4x4
3.6L Pentastar® VVT V6	8-speed	3.21	4309 (9500)	2177 (4800)	2018 (4450)	2087 (4600)	2019 (4450)	2019 (4450)	1928 (4250)	1950 (4300)	1860 (4100)		
		3.55	5443 (12,000)	3311 (7300)	3221 (7100)								
		3.55	5534 (12,200)			3311 (7300)	3243 (7150)						
		3.55	5670 (12,500)					3379 (7450)	3289 (7250)	3357 (7400)	3266 (7200)		
5.7L HEMI® V8	6-speed	3.21	5489 (12,100)	3243 (7150)		3175 (7000)		3084 (6800)					
		3.55	6418 (14,150)	4173 (9200)	4105 (9050)	4105 (9050)	4014 (8850)	4014 (8850)	3924 (8650)	3992 (8800)	3901 (8600)	3969 (8750)	3901 (8600)
		3.92	6396 (14,100)	4150 (9150)	4082 (9000)								
		3.92	7099 (15,650)			4740 (10,450)	4695 (10,350)	4695 (10,350)	4604 (10,150)	4672 (10,300)	4581 (10,100)	4649 (10,250)	4559 (10,050)
	8-speed	3.21	6124 (13,500)	3901 (8600)	3810 (8400)	3833 (8450)	3720 (8200)	3742 (8250)	3629 (8000)	3720 (8200)	3606 (7950)	3674 (8100)	3606 (7950)
		3.92	6396 (14,100)	4173 (9200)	4082 (9000)								
		3.92	7099 (15,650)			4740 (10,450)	4695 (10,350)	4717 (10,400)	4604 (10,150)	4695 (10,350)	4559 (10,000)	4649 (10,250)	4559 (10,050)
		3.92	7099 (15,650)										
PAYLOAD,* kg (lb)				Regular Cab				Quad Cab		Crew Cab			
Engine	Auto Trans	Axle Ratios	GVWR	1.9m (6'4") Box		2.4m (8') Box		1.9m (6'4") Box		1.7m (5'7") Box		1.9m (6'4") Box	
3.6L Pentastar VVT V6	8-speed	3.21, 3.55	2733 (6025)	4x2	4x4	4x2	4x4	4x2	4x4	4x2	4x4	4x2	4x4
			2858 (6300)	685 (1510)									
			2994 (6600)		721 (1590)		862 (1900)						
			3039 (6700)						826 (1820)		803 (1770)		
5.7L HEMI V8	6-speed	3.21, 3.55, 3.92	3084 (6800)					875 (1930)		785 (1730)		762 (1680)	
			2880 (6350)	730 (1610)	649 (1430)								
			2994 (6600)			776 (1710)	676 (1490)						
			3084 (6800)					776 (1710)	676 (1490)	748 (1650)	762 (1680)	716 (1580)	635 (1400)
8-speed	3.21, 3.92	3.21, 3.92	2880 (6350)	739 (1630)	658 (1450)								
			2994 (6600)			785 (1730)	680 (1500)						
			3084 (6800)					785 (1730)	680 (1500)	758 (1670)	658 (1450)	725 (1600)	644 (1420)
			3084 (6800)										
DIESEL ENGINE													
3.0L ECODIESEL V6 (when properly equipped)				REGULAR CAB				QUAD CAB		CREW CAB			
				2.4m (8') Box		1.9m (6'4") Box		1.7m (5'7") Box		1.9m (6'4") Box			
Max Tow Capacity				4,173 kg (9,200 lb)				4,105 kg (9,050 lb)		4,060 kg (8,950 lb)		4,037 kg (8,900 lb)	
Payload Capacity				717 kg (1,580 lb)				649 kg (1,430 lb)		667 kg (1,470 lb)		635 kg (1,400 lb)	

*Maximum capability ratings shown are based on properly equipped trucks, optional equipment may be necessary; weight of additional options, equipment, passengers and cargo must be deducted from these weights.

DIMENSIONS



INTERIOR DIMENSIONS, mm (in)	REGULAR CAB		QUAD CAB		CREW CAB	
	4x2	4x4	4x2	4x4	4x2	4x4
Headroom F/R	1013 (39.9) / N/A		1041 (41.0) / 1008 (39.7)		1041 (41.0) / 1013 (39.9)	
Legroom F/R	1041 (41.0) / N/A		1041 (41.0) / 880 (34.7)		1041 (41.0) / 1023 (40.3)	
Shoulder Room F/R	1679 (66.0) / N/A		1676 (66.0) / 1668 (65.7)		1676 (66.0) / 1668 (65.7)	
Hip Room F/R	1599 (62.9) / N/A		1605 (63.2) / 1599 (62.9)		1605 (63.2) / 1605 (63.2)	
Total Interior Volume Litres (cu ft)	1770 (62.5)		3302 (116.6)		3548 (125.3)	
EXTERIOR DIMENSIONS, mm (in)	REGULAR CAB		QUAD CAB		CREW CAB	
	1.9m (6'4") Box	2.4m (8') Box	1.9m (6'4") Box	1.7m (5'7") Box	1.9m (6'4") Box	
Wheelbase	3061 (120.5)	3569 (140.5)	3569 (140.5)	3569 (140.5)	3794 (149.5)	
Overall Length	5309 (209.0)	5867 (231.0)	5817 (229.0)	5817 (229.0)	6030 (237.4)	
Overall Height (empty) 4x2/4x4	1894 (74.6) / 1910 (75.2)	1889 (74.4) / 1906 (75.0)	1906 (75.1) / 1923 (75.7)	1907 (75.1) / 1923 (75.7)	1872 (73.7) / 1974 (77.7)	
Overall Body Width (without mirrors)	2017 (79.4)		2017 (79.4)		2018 (79.4)	
Track — Front 4x2/4x4	1728 (68.0) / 1732 (68.2)	1728 (68.0) / 1732 (68.2)	1729 (68.0) / 1732 (68.2)	1730 (68.0) / 1732 (68.2)	1742 (68.6) / 1736 (68.3)	
Track — Rear 4x2/4x4	1715 (67.5) / 1715 (67.5)	1716 (67.5) / 1715 (67.5)	1717 (67.5) / 1715 (67.5)	1718 (67.5) / 1715 (67.5)	1732 (68.2) / 1732 (68.2)	
Turning Diameter 4x2/4x4	12 (39.5) / 12.1 (39.8)	13.7 (45.1) / 13.8 (45.4)	13.7 (45.1) / 13.8 (45.4)	13.7 (45.1) / 13.8 (45.4)	13.7 (45.1) / 13.8 (45.4)	
Bed Length (at floor)	1939 (76.3)	2497 (98.3)	1936 (76.3)	1712 (67.4)	1936 (76.3)	
Bed Height	511 (20.1)	513 (20.2)	511 (20.1)	509 (20.0)	511 (20.1)	
Bed Width at Wall	1687 (66.4)	1687 (66.4)	1687 (66.4)	1687 (66.4)	1687 (66.4)	
Bed Width at Wheelhousings	1295 (51.0)	1295 (51.0)	1295 (51.0)	1295 (51.0)	1295 (51.0)	

For the most up-to-date specifications, visit RAMBODYBUILDER.COM





ABOUT THIS CATALOGUE: Since the time of printing, some of the information you'll find in this catalogue may have been updated. Ask your retailer for details. Some of the equipment shown or described throughout this catalogue may be available at extra cost. Specifications, descriptions, illustrative materials and all competitive comparisons contained herein are as accurate as known at the time this publication was approved for printing. Chrysler Canada Inc. reserves the right to discontinue models at any time or change specifications without notice or without incurring obligation. For the price of the model with the equipment you desire, or verification of specifications contained herein, see your Ram retailer. Chrysler, Jeep, Dodge, Ram, Big Horn, Express, HEMI, Laramie, Laramie Longhorn, Mopar, Outdoorsman, ParkView, Park-Sense, Quad Cab, R/T, RamBox, the Ram's Head logo, SLT, Sport Tradesman, ST and SXT are registered trademarks, and Active-Level, Keyless Enter 'n Go, Pentastar, TorqueFlite and Uconnect are trademarks of Chrysler Canada Inc. iPod is a registered trademark of Apple Inc. Bluetooth is a registered trademark of Bluetooth SIG, Inc. SIRIUS and all related marks and logos are registered trademarks of SiriusXM Radio and its subsidiaries. Alpine and the Alpine logo are registered trademarks of Alpine Electronics, Inc. BorgWarner is a trademark of BorgWarner Inc. Goodyear is a registered trademark of The Goodyear Tire & Rubber Company.

WARRANTIES: 2014 Chrysler, Jeep, Dodge and Ram vehicles are backed by a 5-year or 100,000-kilometre* fully transferable Powertrain Limited Warranty with \$0 deductible plus 24-hour roadside assistance.* Basic Warranty coverage is for 3 years or 60,000 kilometres.* Rust-through coverage on all body sheet metal is for 3 years.

*Whichever comes first. Some conditions may apply. †The 5-Year/100,000-Kilometre Powertrain Limited Warranty does not apply to vehicles sold for certain commercial uses. See your retailer for full details.

CHRYSLER SERVICE CONTRACTS: Chrysler Canada Inc. has a vested interest in your satisfaction and owner experience with your new Ram truck. Chrysler Canada Service Contracts offer extended service plans to help ensure that you'll enjoy your truck for many years down the road. For more information on comprehensive vehicle coverage, see your Ram retailer, call 800-465-2001, or visit chryslercanada.ca/owners

DISCLAIMERS: ^[1]Based on longevity of entire Ram large pickup segment compared to all competitive large pickups on the road since 1988. Longevity based on R.L. Polk Canada, Inc. Canadian Vehicles in Operation data as of July 1 for model years 1988–2012 for all large pickups sold and available in Canada over the last 25 years. ^[2]Based on *Automotive News* Full-Size Pickup Segmentation. Based on Chrysler estimated highway fuel consumption ratings. Your actual fuel consumption will vary based on driving habits and other factors. ^[3]Based on *Automotive News* Full-Size Pickup Segmentation and competitive information available at time of printing. ^[4]Based on *Automotive News* Full-Size Pickup Segmentation. Based on *EnerGuide* highway fuel consumption ratings. Government of Canada test methods used. Your actual fuel consumption will vary based on driving habits and other factors. 11.4 L/100 km (25 mpg) city and 7.8 L/100 km (36 mpg) hwy on HFE model with 3.6L V6 and 8-speed automatic. Ask your retailer for *EnerGuide* information. ^[5]Always check entire surroundings before manoeuvring your vehicle. ^[6]No system can repeal the laws of physics or overcome careless driving actions. Performance is limited by available traction, which snow, ice and other conditions can affect. When the warning lamp flashes, the driver needs to use less throttle and adapt speed and driving behaviour to prevailing road conditions. ^[7]Requires SiriusXM radio subscriptions governed by SIRIUS terms and conditions available at siriusxm.ca ^[8]Driving while distracted can result in loss of vehicle control. Only use mobile phones and other devices, even with voice commands, when it is safe to do so. Voice commands of phone require a Bluetooth compatible phone. ^[9]Phone must support Bluetooth Phone Book Access Profile (PBAP). ^[10]Never program while driving. GPS mapping and available 3D navigation may not be detailed or available in all areas or reflect current road regulations. ^[11]The advanced front air bags in this vehicle are certified to the federal regulations for advanced air bags. Children 12 years old and younger should always ride buckled up in a rear seat. Infants in rear-facing child restraints should never ride in the front seat of a vehicle with a passenger front air bag. All occupants should always wear their lap and shoulder belts properly. ^[12]Not compatible with all garage door openers. ^[13]Preset voice to text and incoming text message reading requires a MAP enabled phone. ^[14]Transferable. See your retailer for complete details and a copy of the 5-Year/100,000-Kilometre Powertrain Limited Warranty. ^[15]Oil change intervals will vary based on excessive engine run times, operating conditions, maintenance schedules and driving habits. Excluding diesel engines with biodiesel fuels.

RAMTRUCK.CA 800-361-3700

Ram is a registered trademark of Chrysler Group LLC.

Form no. 52014C471E / Printed in Canada.

